

# BC1 - Box Computer with Dual Graphics Connection



- **AMD T52R, 1.5 GHz with up to 4 GB DDR3 RAM**
- **2 DisplayPort® interfaces, up to 2560x1600 each**
- **2 Gigabit Ethernet on M12 connectors**
- **1 USB 2.0**
- **SD card (2 GB pre-installed) and mSATA slots**
- **2 PCI Express® Mini Card slots for WLAN, UMTS, GPS, GSM, HSDPA, EDGE, LTE**
- **2 SA-Adapter™ slots for 2 UARTs (optionally 1 IBIS/GPS, 1 CAN)**
- **24 VDC nom. (9 to 36 V) class S2 power supply**
- **-40 to +70(+85)°C operating temperature**
- **EN 50155, prepared for e1, up to IP40**

The BC1 is a maintenance-free box computer that has been designed for independent use or as display computer electronics for use in railway applications, commercial vehicles, mobile machines, avionics and mission-critical industrial control systems with visualization requirements.

It is powered by an AMD Embedded G-Series APU (Accelerated Processing Unit), the T52R, running at 1.5 GHz. The G-Series combines low-power CPUs and advanced GPUs, in this case an AMD Radeon™ HD 6310, into a single embedded device. The use of the Embedded G-Series makes for high scalability in CPU (single/dual core) and graphics performance (various Radeon™ GPUs or none at all).

The BC1 is equipped with 1 GB of DDR3 SDRAM, comes with a pre-installed 2-GB SD card and also offers an mSATA slot. A SATA hard-disk/solid-state drive can be installed within the housing as an option. The system is designed for fanless operation at temperatures from -40 to +70°C (+85°C for up to 10 minutes), its special aluminum housing with cooling fins serves as a heatsink for the internal electronics and in this way provides conduction cooling.

The BC1 supports up to two DisplayPort® interfaces with a maximum resolution of 2560x1600 each, DisplayPort® 1 with an AUX channel and hot plug

detection and DisplayPort® 2 with a USB channel. The AUX channel of DisplayPort® 1 can optionally be used for USB signals as well, e.g., to realize touch functionality. The DisplayPort® interfaces and all other I/O are available at the unit's front panel on standard connectors like USB, 9-pin D-Sub (HD audio and optional serial I/O), 8-pin M12 (Gigabit Ethernet) and DisplayPort®. On the inside, the system offers two PCI Express® Mini card slots with two SIM card slots. By default, one is used for each of the two PCI Express® Mini cards, but the first PCI Express® Mini card can also switch between the two SIM cards as an option. The necessary antenna connectors can be made available at the front panel.

The BC1 comes with its own integrated 30W 24 VDC nom. (9 to 36 V) class S2 wide-range power supply and is compliant with EN 50155 and prepared for e1 certification. If the connected display panels require more power, an external PSU can be connected via a power bypass connector within the unit to supply the necessary 12 VDC internal voltage for the system.

The combination of the various CPU/GPU options with the available selection of external interfaces (realized via separate graphics and I/O interface boards within the system) makes for an extremely flexible system design that can quickly be tailored to a vast number of applications.

## Technical Data

### CPU

- AMD Embedded G-Series T52R
  - 1.5 GHz processor core frequency
  - Accelerated Processing Unit (APU), also includes GPU (see Graphics)

### Controller Hub

- AMD ASSE

### Memory

- 64KB L1 and 512KB L2 cache
- 1 GB DDR3 SDRAM system memory
  - Soldered
  - 1333 MT/s (667 MHz)

### Mass Storage

- One SD card slot
  - 2-GB SD card pre-installed
  - Via USB
- One mSATA slot
  - Transfer rate up to 3Gb/s
- Serial ATA (SATA) interface
  - One port for hard-disk/solid-state drive mounted within the unit's housing
  - Third generation, transfer rate up to 6Gb/s

### Graphics

- AMD Radeon™ HD 6310
  - Dual independent display support
  - Dual DisplayPort®
  - Maximum resolution: 2560x1600
  - Embedded in T52R APU
- 3D Graphics Acceleration
  - Full DirectX® 11 support, including full speed 32-bit floating point per component operations
  - Shader Model 5
  - OpenCL™ 1.1 support
  - OpenGL® 4.0 support
- Motion Video Acceleration
  - Dedicated hardware (UVD 3) for H.264, VC-1 and MPEG2 decoding
  - HD HQV and SD HQV support: noise removal, detail enhancement, color enhancement, cadence detection, sharpness, and advanced de-interlacing
  - Super up-conversion for SD to HD resolutions

### Front I/O

- 2 DisplayPort® 1.1a interfaces
  - DisplayPort® 1 with AUX channel and hot plug detection
  - DisplayPort® 2 with USB channel
- 1 HD audio
  - HD audio codec

- Audio stereo in
- Audio stereo out
- SPDIF out
- All available via 9-pin D-Sub connector
- 2 Gigabit Ethernet
  - Via M12 connectors
- 1 USB 2.0
  - Via Series A connector
- 2 SA-Adapter™ slots for serial I/O
  - 1 UART or IBIS, GPS
  - 1 UART or CAN bus
- 6 status LEDs
  - 4 for Ethernet link and activity status
  - 2 for general board status

### 2 PCI Express® Mini Card slots

- For functions like WIFI, WIMAX, GSM/GPRS, UMTS
- 2 SIM card slots
- PCI Express® and USB interface

### Electrical Specifications

- Isolation voltage 1,500 VDC
  - Ethernet port 1, Ethernet port 2, audio interface, power input, USB interface
- Supply voltage:
  - 24 VDC nom. (9 to 36 V)
  - EN 50155 power interruption class S2
- Power consumption: Up to 25 W

### Mechanical Specifications

- Dimensions: approx. 250 mm x 220 mm x 44.1 mm
- Weight: 1.8 kg
- Front protected according to IP20
- Sides protected according to IP40

### Environmental Specifications

- Temperature range (operation):
  - -40°C to 70°C (screened), with up to 85°C for 10 minutes according to class Tx (EN 50155)
  - Fanless operation
- Temperature range (storage): -40..+85°C
- Relative humidity (operation): max. 95% non-condensing
- Relative humidity (storage): max. 95% non-condensing
- Altitude: -300 m to +3,000 m
- Shock: 50 m/s<sup>2</sup>, 30 ms
- Vibration (function): 1 m/s<sup>2</sup>, 5 Hz - 150 Hz
- Vibration (lifetime): 7.9 m/s<sup>2</sup>, 5 Hz - 150 Hz
- Conformal coating of internal components on request

## Technical Data

### MTBF

- 262,804 h (tbc.) @ 40°C according to IEC/TR 62380 (RDF 2000)

### Safety

- PCB manufactured with a flammability rating of 94V-0 by UL recognized manufacturers

### EMC

- Conforming to EN 55022 (radio disturbance), IEC 61000-4-2 (ESD) and IEC 61000-4-4 (burst)
- Prepared for certification according to e1 requirements of the German Federal Motor Transport Authority

### BIOS

- InsydeH2O™ UEFI Framework

### Software Support

- Windows® 7
- Windows® Embedded Standard 7
- Linux
- [For more information on supported operating system versions and drivers see Software.](#)

# Diagram

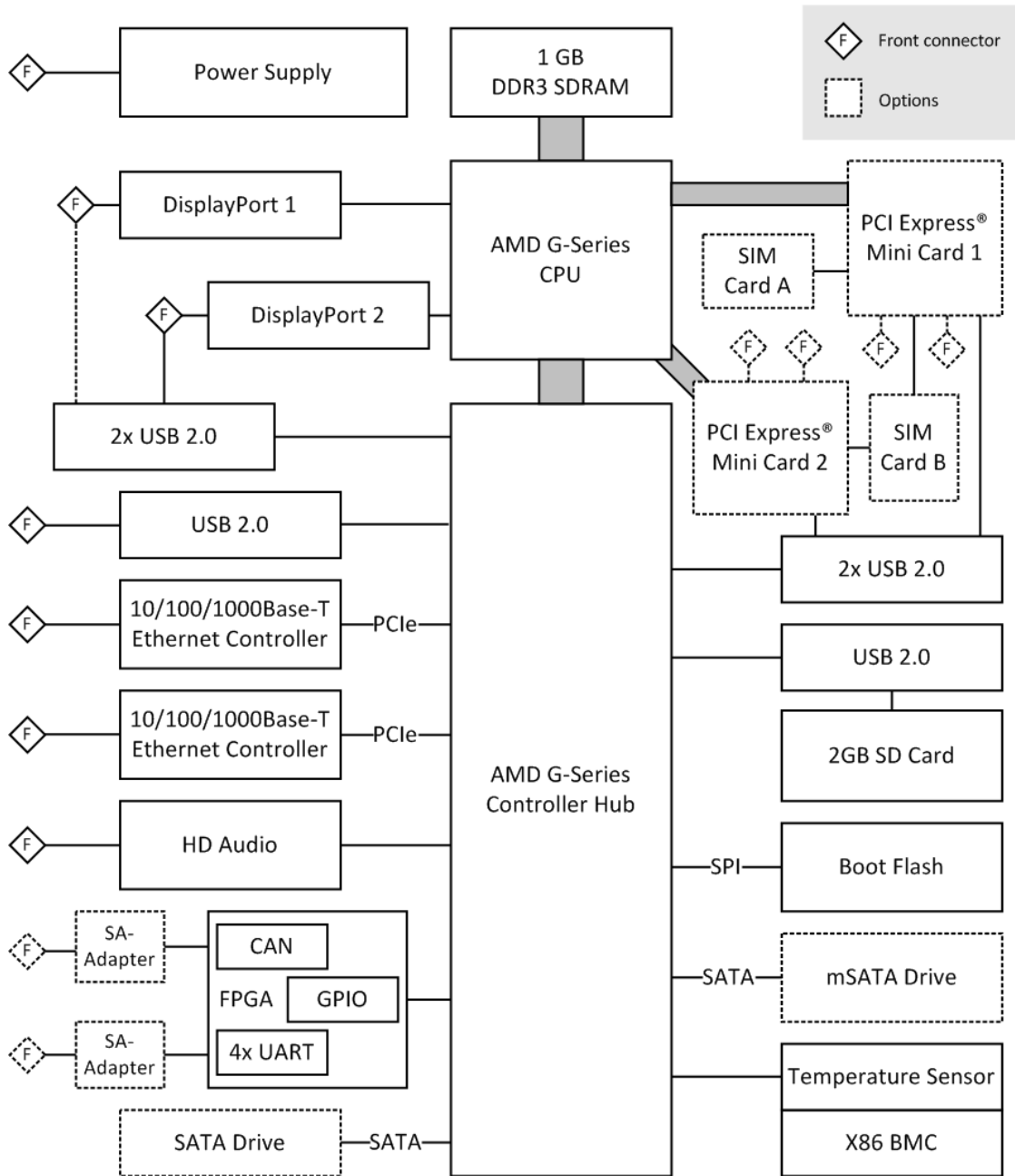

## Configuration & Options

### Standard Configurations

Article No.	APU	Graphics	Memory	Input Voltage	HD Audio	Antenna Connectors	SATA HDD/SSD
09BC01-00	AMD T52R, 1.5 GHz Single Core (18W)	AMD Radeon™ HD 6310	1 GB DDR3-1333, 64KB L1 cache, 512kB L2 cache	24 VDC nom.	Yes	No	No

### Options

#### APU

- AMD T56N, 1.65 GHz Dual Core (L1 cache 64KB, L2 cache 512kB x2, 18W), DDR3-1333, AMD Radeon™ HD 6320
- AMD T52R, 1.5 GHz Single Core (L1 cache 64KB, L2 cache 512kB, 18W), DDR3-1333, AMD Radeon™ HD 6310
- AMD T48N, 1.4 GHz Dual Core (L1 cache 64KB, L2 cache 512kB x2, 18W), DDR3-1066, AMD Radeon™ HD 6310
- AMD T40N, 1.0 GHz Dual Core (L1 cache 64KB, L2 cache 512kB x2, 9W), LVDDR3-1066, AMD Radeon™ HD 6290
- AMD T44R, 1.2 GHz Single Core (L1 cache 64KB, L2 cache 512kB, 9W), LVDDR3-1066, AMD Radeon™ HD 6250
- AMD T40E, 1.0 GHz Dual Core (L1 cache 64KB, L2 cache 512kB x2, 6.4W), LVDDR3-1066, AMD Radeon™ HD 6250
- AMD T40R, 1.0 GHz Single Core (L1 cache 64KB, L2 cache 512kB, 5.5W), LVDDR3-1066, AMD Radeon™ HD 6250

#### Memory

- Up to 4 GB DDR3 SDRAM system memory
- SATA hard-disk/solid state drive (mounted within housing)

#### Graphics

- Maximum resolution depending on GPU
  - 2560x1600 (all DisplayPort® interfaces) with Radeon™ HD 6310 and 6320
  - 1920x1200 (all DisplayPort® interfaces) with Radeon™ HD 6250 and 6290

#### I/O

- Antenna connectors
  - For functions like WIFI, WIMAX, GSM/GPRS, UMTS in combination with PCI Express® Mini Card(s)
  - Reverse SMA connector

#### Electrical Specifications

- Input voltage 36 VDC nom.

#### Mechanical Specifications

- Front protected according to IP40

#### Environmental Specifications

- Temperature range (operation):
  - -40°C to 85°C (screened) with wider housing with additional cooling fins

#### Software Support

- Windows® XP Embedded (on request)

**As the product concept is very flexible, there are many other configuration possibilities. Please contact our sales team if you do not find your required function in the options. Please note that some of these options may only be available for large volumes.**

## Ordering Information

### Standard BC1 Models

**09BC01-00** Box computer with dual graphics connection, 24 VDC PSU, AMD T52R, 1.5 GHz, 1 GB RAM, 2 GB SD card, mSATA slot, 2x DisplayPort, 2x Gb Ethernet, 1x USB, 2x SA-Adapter slot (UARTs, fieldbuses), 2x PCI Express Mini card slot, 2x SIM card slot, -40..+70(+85)°C screened, IP40, EN 50155, prepared for e1

### Memory

**0751-0048** SSD mSATA, 4 GB, 0..+70°C

### SA-Adapters

**08SA01-06** RS232, not optically isolated, -40..+85°C screened

**08SA02-07** RS422/485, full duplex, optically isolated, -40..+85°C screened

**08SA03-01** RS232, optically isolated, -40..+85°C screened

**08SA08-01** CAN ISO high-speed, optically isolated, -40..+85°C screened

**08SA22-00** IBIS master SA-Adapter, -40..+85°C screened

**08SA22-01** IBIS slave SA-Adapter, -40..+85°C screened

**08SA25-00** GPS receiver, isolated, -40..+85°C screened

**08SA26-00** RS422 with 15-pin D-Sub connector, with handshake signals (RTS, CTS, DCD, DTR), coated, -40..+85°C screened

### Miscellaneous Accessories

**0780-0005** DisplayPort to DVI-D Adapter, 20 cm

### Documentation

**09BC01-DS** BC1 Data Sheet

For the most up-to-date ordering information and direct links to other data sheets and downloads, see the BC1 online data sheet under » [www.men.de](http://www.men.de).

## Contact Information

### Germany

MEN Mikro Elektronik GmbH  
 Neuwieder Straße 3-7  
 90411 Nuremberg  
 Phone +49-911-99 33 5-0  
 Fax +49-911-99 33 5-901  
 E-mail info@men.de  
 www.men.de

### France

MEN Mikro Elektronik SA  
 18, rue René Cassin  
 ZA de la Châtelaïne  
 74240 Gaillard  
 Phone +33 (0) 450-955-312  
 Fax +33 (0) 450-955-211  
 E-mail info@men-france.fr  
 www.men-france.fr

### USA

MEN Micro, Inc.  
 24 North Main Street  
 Ambler, PA 19002  
 Phone (215) 542-9575  
 Fax (215) 542-9577  
 E-mail sales@menmicro.com  
 www.menmicro.com

*The date of issue stated in this data sheet refers to the Technical Data only. Changes in ordering information given herein do not affect the date of issue.*

*All brand or product names are trademarks or registered trademarks of their respective holders.*

*MEN is not responsible for the results of any actions taken on the basis of information in the publication, nor for any error in or omission from the publication.*

*MEN expressly disclaims all and any liability and responsibility to any person, whether a reader of the publication or not, in respect of anything, and of the consequences of anything, done or omitted to be done by any such person in reliance, whether wholly or partially, on the whole or any part of the contents of the publication.*

*The correct function of MEN products in mission-critical and life-critical applications is limited to the environmental specification given for each product in the technical user manual. The correct function of MEN products under extended environmental conditions is limited to the individual requirement specification and subsequent validation documents for each product for the applicable use case and has to be agreed upon in writing by MEN and the customer. Should the customer purchase or use MEN products for any unintended or unauthorized application, the customer shall indemnify and hold MEN and its officers, employees, subsidiaries, affiliates, and distributors harmless against all claims, costs, damages, and expenses, and reasonable attorney fees arising out of, directly or indirectly, any claim or personal injury or death associated with such unintended or unauthorized use, even if such claim alleges that MEN was negligent regarding the design or manufacture of the part.*

*In no case is MEN liable for the correct function of the technical installation where MEN products are a part of.*

Copyright © 2011 MEN Mikro Elektronik GmbH. All rights reserved.

